

Express & Savana

UPFIT GUIDE



WORK VEHICLES THAT WORK BETTER!





Who We Are

Advantage Outfitters is a commercial vehicle upfitter, specializing in storage equipment and accessories for cargo vans. With 15+ years of experience, we have earned the trust of contractors, trade fleets, utilities, municipalities, vehicle dealers, and leasing companies. We are defined by our strong team spirit and our passion for making our customers happy. Our entire team is committed to making your work vehicles work better!

Our Team



*Real People.
Real Passion.*

Our Service



Our Facilities



866.925.4844

fax: 800.925.2095

sales@advantageoutfitters.com

www.advantageoutfitters.com

New York • New Jersey • Connecticut

What's the Advantage?

We make it easy:

- Simplified layout and design process
- Technical support and configuration assistance

We make it fast:

- Everything in this catalog is in stock
- Installs within 48 hours or less

We make it last:

- Certified and trained Installers
- Lifetime Installation Warranty

Read what our customers say about us!

"they are a well coordinated team, from sales to technical support to installation"

–David M.

"very well run and efficient operation, AAA+++ customer service"

–Eric S.

"great deal and very smooth transaction, everyone was very helpful with my order from start to finish"

–Nick C.

"I couldn't have been more impressed with their attention to detail"

–Daniel S.

"superb customer service"

–Glenn M.

Onsite Installation Available!



Interior Finishing



Wall & Door Liners

- Protect your vehicle investment
- 3/16" gray plastic
- Highly durable & impact resistant

Note: Full interior liner kits and insulation kits are available. Call for details.



Model	Wall Liners Part#
Regular WB	601G1WL
Extended WB	601G2WL

Description	Door Panels Part#
Rear doors & side sliding door	601GXDP
Rear doors & side barn/hinged doors	601GXDPB



INTERIOR FINISHING

Logistics Kits

Aluminum Lashing Rail

- Durable & versatile
- Includes 5 movable tie-down rings
- Ratchet straps also available



Description	Regular WB Part#	Extended WB Part#
Single Level L-Track	842G1LK	842G2LK

Floor Protection

StabiliGrip Floor:

- 3/8" hard plastic with fiberglass reinforcement
- Provides firm base for tools and equipment
- Durable, non-skid surface



StabiliGrip Floor

Diamond Plate Aluminum:

- 1/8" aluminum for lasting durability
- Superior impact & puncture resistance



Diamond Plate Aluminum

Door Sills (optional):

- Custom fit, heavy-duty diamond plate aluminum sill plates



Side Door Sill (optional)



Rear Door Sill (optional)

Model	StabiliGrip Floor Part#	Diamond Plate Aluminum Part#
Regular WB	654G1SG	698G1DP
Extended WB	654G2SG	698G2DP

Description	Door Sill Part#
Rear & Side Sliding Doors	654GXRSS

Interior Lighting

- High intensity 2' LED light
- 800 lumens
- Ultra low power draw
- Wired with OEM switch



Description	Part#
Single 2' LED light	452XXLD2

Safety Partitions



SAFETY & SECURITY



Straight Partition

- Galvanized steel
- Mesh upper for visibility into rear

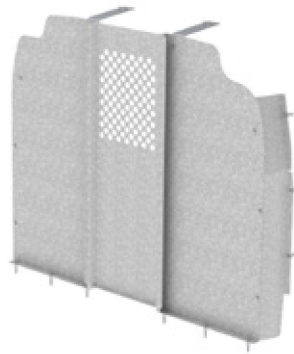

Description	Part#
Straight Partition	276GXSP

Swing Door Partition

- Galvanized steel
- Hinged door with latch
- Mesh upper for visibility into rear

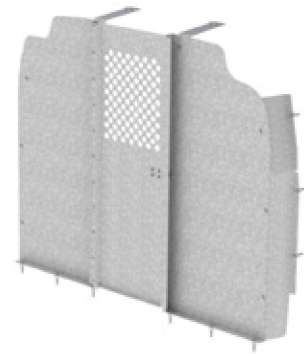

Description	Part#
Swing Door Partition	276GXHDP

Contoured Solid Partition

- Galvanized steel
- Contoured design with 5" setback gives maximum seatback travel & floor space
- Solid panel for maximum security



Description	Part#
Contoured Solid Partition	276GXCP

Contoured Partition with Window

- Galvanized steel
- Contoured design with 5" setback gives maximum seatback travel & floor space
- Mesh upper for visibility into rear



Description	Part#
Contoured Partition with Window	276GXWP

Door Security

Slick Locks

- High security hasps use factory mounting points
- Solid steel “puck” style locks included
- Custom fit for drill-free installation



Description	Part#
Cargo Doors (set of 2, rear doors & side sliding door)	788GXSLs
Cargo Doors (set of 2, rear doors & side barn/hinged doors)	788GXSLH

Reverse/Driving Safety

Reverse Sensors

- 4 bumper mount sensors
- Digital LED display with audio alarm



Description	Part#
Reverse Sensors	580XXRVS

Back-up Alarm

- 97 dba
- Commercial grade



Description	Part#
Back-up Alarm	594XXBU

Window Grills

- Black painted wire mesh construction



Rear Doors



Side Doors (barn/hinged doors only)

Description	Part#
Rear Doors	876GXRG
Side doors (barn/hinged doors only)	876GXSGB



Strong... Lightweight... Quiet... Customizable...

Up to 40% weight savings versus
comparable steel packages

Load tested to 1200 lbs



Here's what our customers say about their upfitted vans

"my technicians are able to keep
the truck organized, which increases
our overall efficiency"

– Michael S.

"you really helped us get the maximum
benefit out of our vehicles"

– Michael R.

"ready-made solutions that are lighter,
stronger, and more durable than anything
we could have come up with"

– Greg W.



Shelving Packages



Base Package



Straight Partition

Driver's side includes:

- (1) 45"H x 84"L 3-shelf shelving unit

Passenger's side includes:

- (1) 45"H x 48"L 3-shelf shelving unit

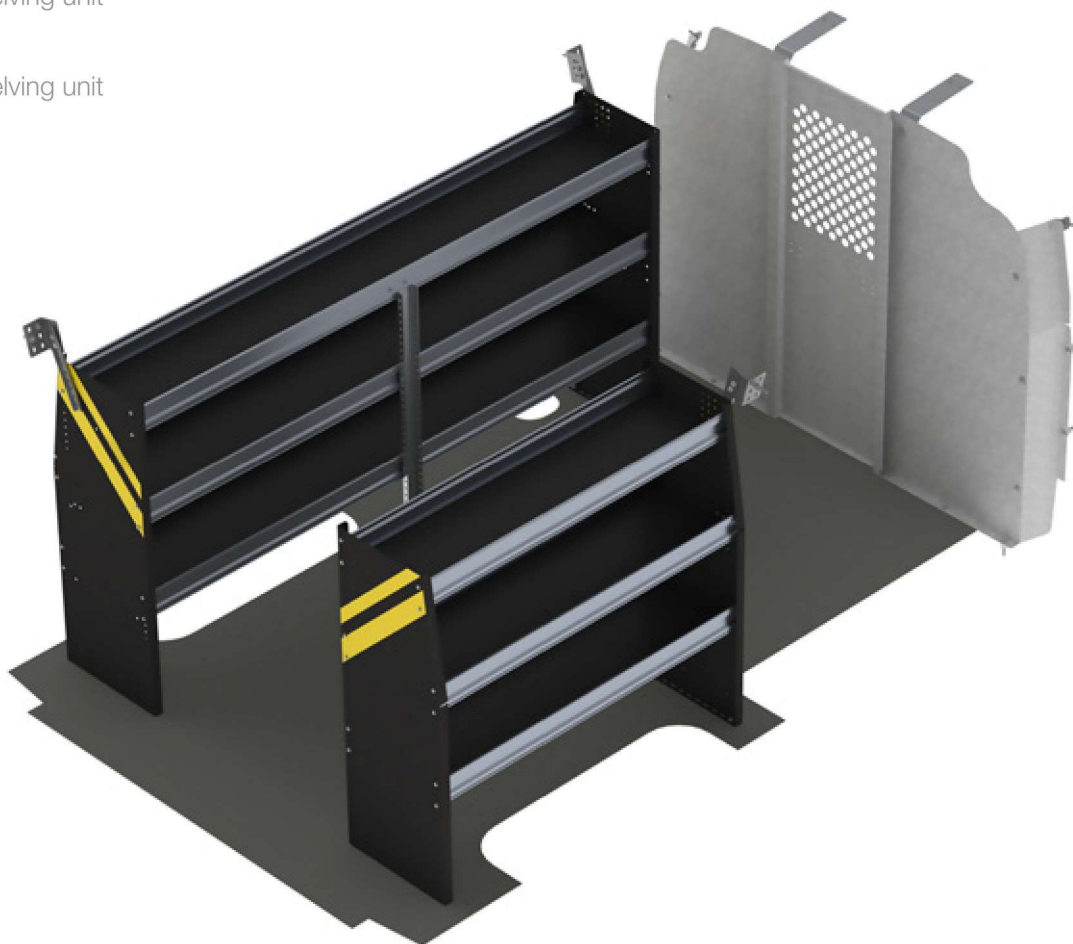

INTERIOR STORAGE & ORGANIZATION

Longer shelving units
available for Extended
Wheelbase

Description	Part#
Base Package (Straight Partition)	276GXBP

General Service Package



Straight Partition

Driver's side includes:

- (1) 45"H x 84"L 3-shelf shelving unit
- (10) adjustable 3" rattle-free dividers
- (2) 18.5"W x 10.5"H 2-drawer cabinets
- (1) fixed hook

Passenger's side includes:

- (1) 45"H x 48"L 3-shelf shelving unit
- (4) 14"D x 12"W plastic bins
- (1) swivel hook

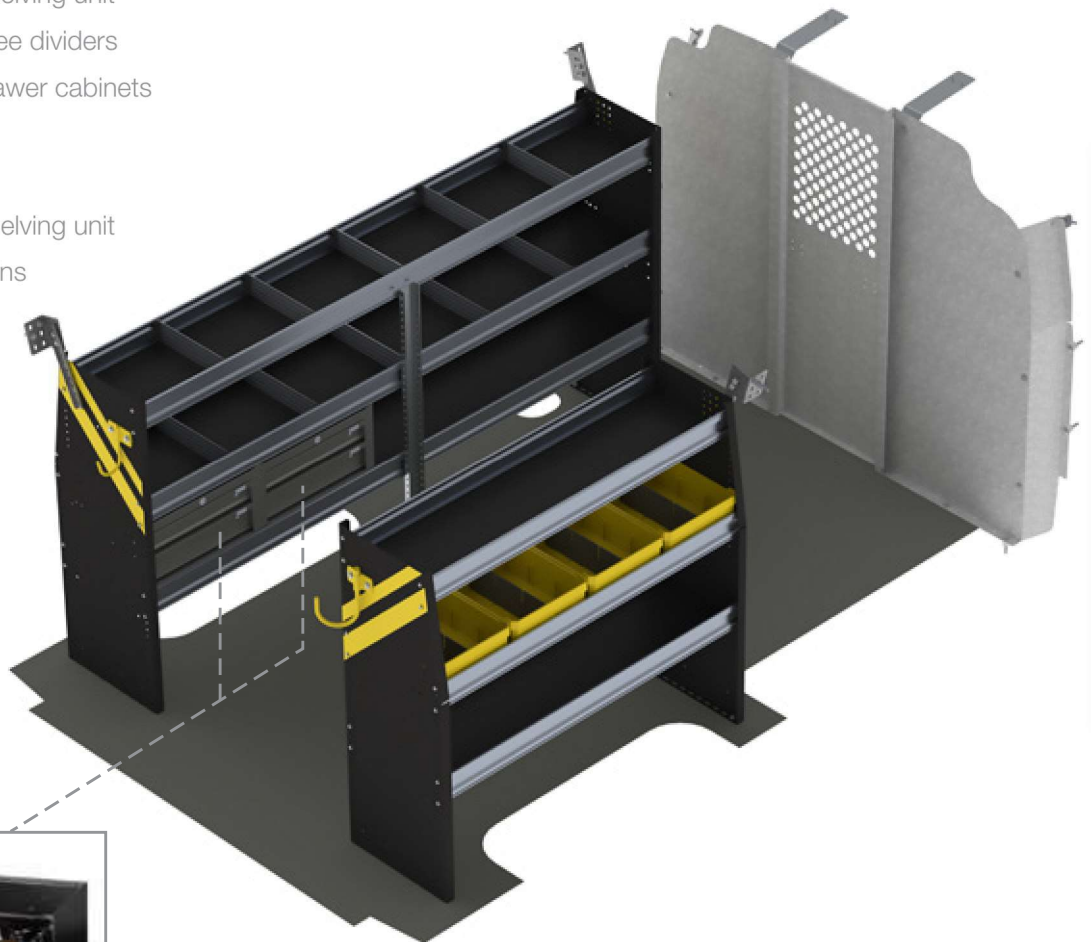

INTERIOR STORAGE & ORGANIZATION

Longer shelving units
available for Extended
Wheelbase

Description	Part#
General Service Package (Straight Partition)	276GXGSP

Shelving Packages



HVAC Package



Straight Partition

Driver's side includes:

- (1) 45"H x 84"L 3-shelf shelving unit
- (7) 14"D x 12"W plastic bins
- (2) 18.5"W x 10.5"H 2-drawer cabinets
- (1) large gas bottle holder
- (1) fixed hook

Passenger's side includes:

- (1) 45"H x 48"L 3-shelf shelving unit
- (10) adjustable 3" rattle-free dividers
- (1) 43"H x 10.5"W 4-tier refrigerant rack for bottles
- (1) swivel hook

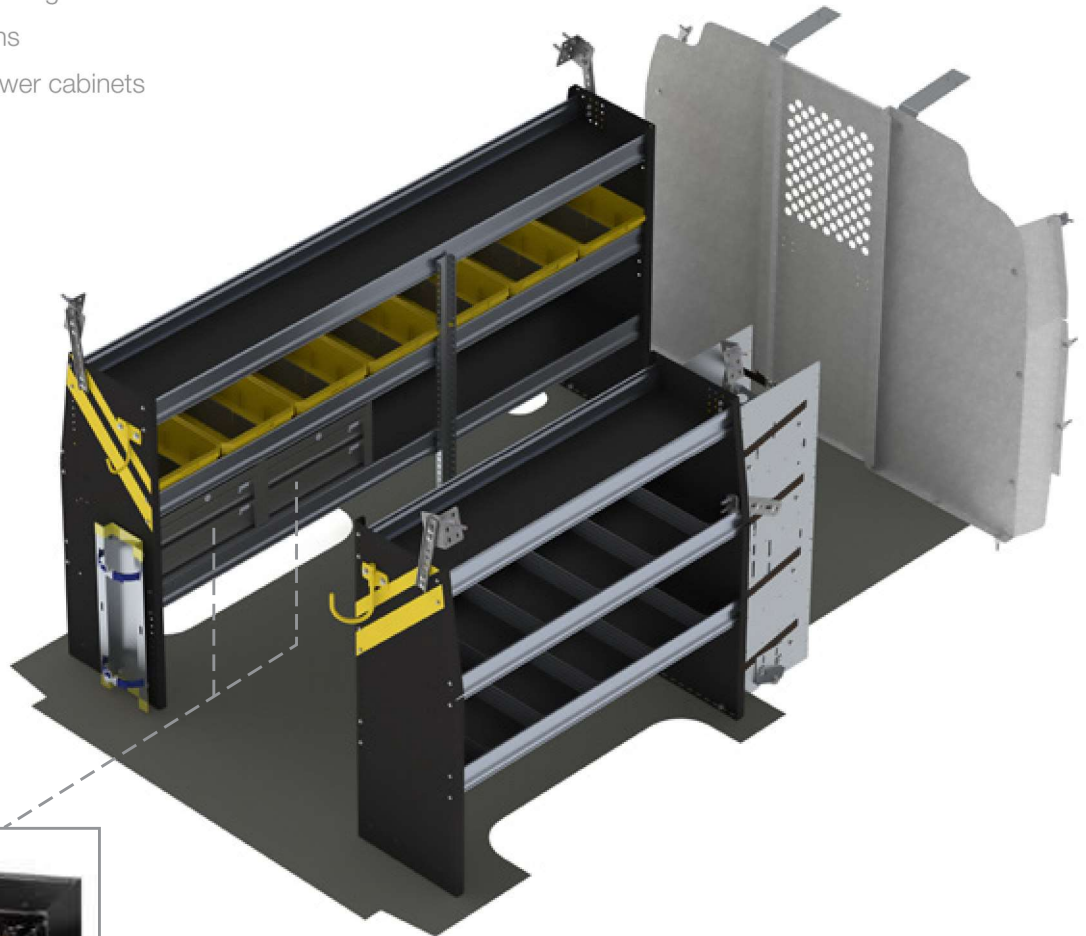

INTERIOR STORAGE & ORGANIZATION

**Longer shelving units
available for Extended
Wheelbase**

Description	Part#
HVAC Package (Straight Partition)	276GXHP

Plumbing Package



Straight Partition

Driver's side includes:

- (1) 45"H x 84"L 3-shelf shelving unit
- (5) adjustable 3" rattle-free dividers
- (1) 18.5"W x 10.5"H 2-drawer cabinet
- (1) 18.5"W x 10.5"H 3-drawer cabinet
- (1) large gas bottle holder
- (1) fixed hook

Passenger's side includes:

- (1) 45"H x 48"L 3-shelf shelving unit
- (8) 14"D x 12"W plastic bins
- (4) cross dividers for bins
- (1) large gas bottle holder
- (1) swivel hook

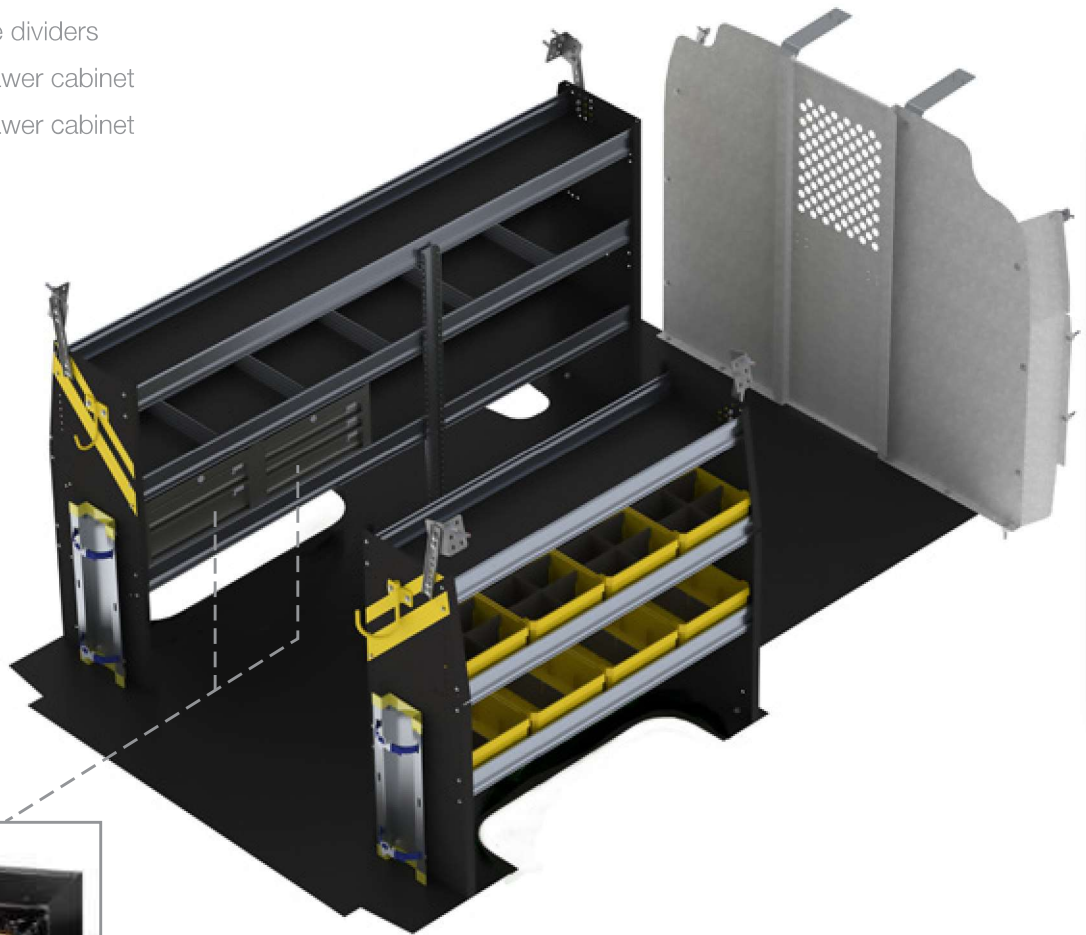

INTERIOR STORAGE & ORGANIZATION

Longer shelving units available for Extended Wheelbase

Description	Part#
Plumbing Service Package (Straight Partition)	276GXPP

Shelving Packages



Electrical Package



Straight Partition

Driver's side includes:

- (1) 45"H x 84"L 3-shelf shelving unit
- (7) 12"D x 12"W plastic bins
- (1) 11"H x 36"L locking cabinet
- (1) 11"H x 48"L locking cabinet
- (1) 18.5"W x 10.5"H 2-drawer cabinet
- (1) 18.5"W x 10.5"H 3-drawer cabinet
- (1) wire reel holder
- (1) fixed hook

Passenger's side includes:

- (1) 45"H x 48"L 3-shelf shelving unit
- (10) adjustable 3" rattle-free dividers
- (1) swivel hook

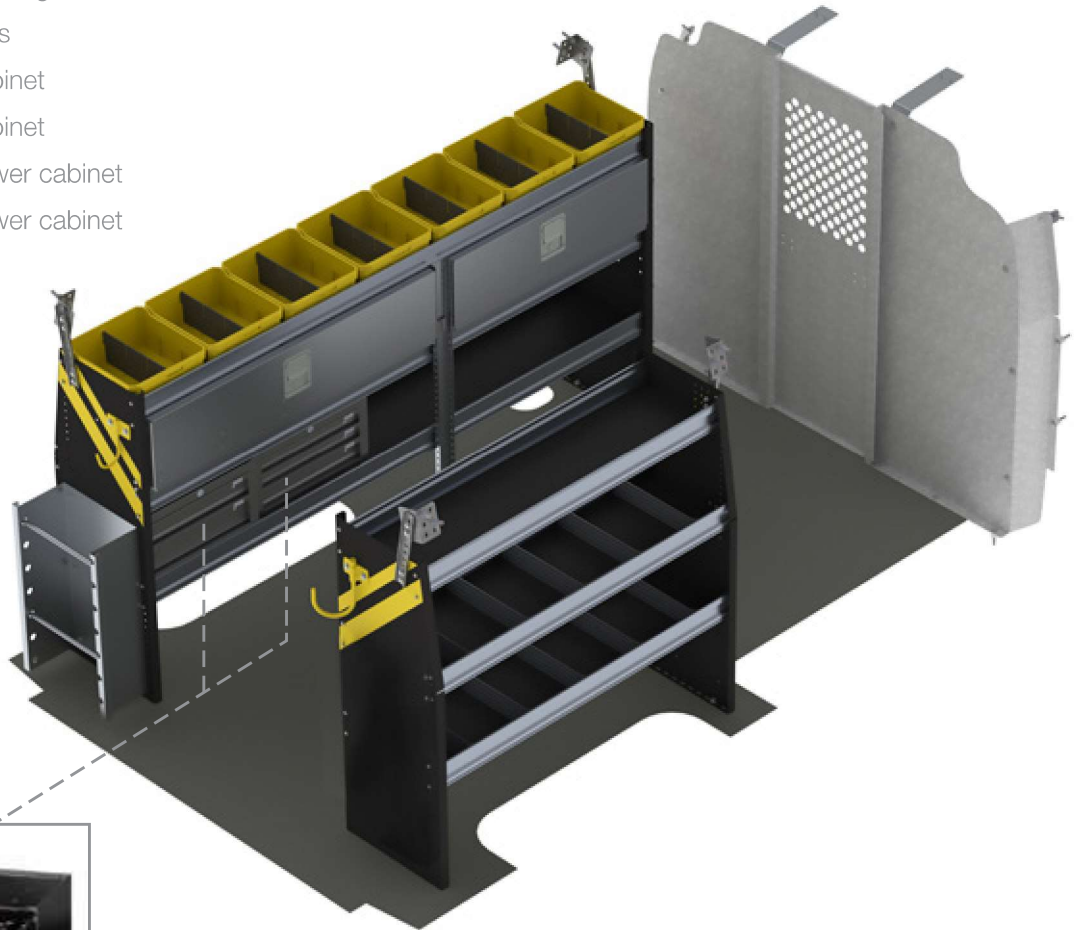

INTERIOR STORAGE & ORGANIZATION

**Longer shelving units
available for Extended
Wheelbase**



Description	Part#
Electrical Package (Straight Partition)	276GXEP

Aluminum Shelving

Ultra-lightweight all-aluminum packages are also available!



Weight saving equipment reduces total cost of ownership:

-  Optimize fuel economy by decreasing overall van mass
-  Reduce vehicle maintenance and repairs caused by weight overload
-  Increase payload without sacrificing quality — it's a benefit offered only by aluminum



INTERIOR STORAGE & ORGANIZATION

Don't See It? Just Ask!

We Also Provide:

- Thermal Insulation
- Exterior Lighting
- Power Inverters
- Climate Control
- Ventilation
- Electrical Systems
- Mobile Workspaces
- Cargo Ramps

And Much More!

Modular Tool & Parts Drawers



Save Time and Get Organized!

Access your most common items without even entering your vehicle.

INTERIOR STORAGE & ORGANIZATION



Jumbo Tool Drawer

- 320 lb capacity
- Open interior for tool bags & cases
- 16"W x 48"L x 20"H



Description	Part#
Jumbo Tool Drawer	176XXJTD

Parts Drawer

- 150 lb capacity
- Dividers for parts and hand tools
- Stack 1, 2 or 3 above your jumbo tool drawer
- 12"W x 48"L x 6"H



Description	Part#
Parts Drawer	176XXPD

Top Tray

- Turn your parts drawer top into additional organization
- Add 3 crates (optional)
- 12"W x 48"L x 4"H



Description	Part#
Top Tray	176XXTT
Top Tray With Crates	176XXTWC

Add a Worktop to Your Drawer System

- 18"D x 48"W hardwood butcher block top



Description	Part#
Drawer System Worktop	176XXWT

Add a Raise For Long Pipe or Lumber

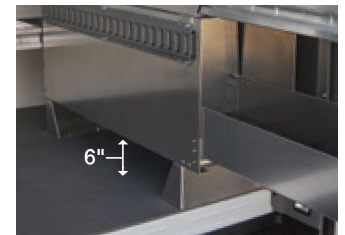

Description	Part#
Raises (set of 2)	176XX6R

Be Efficient!

Saving just 5 minutes per day will gain you 21 hours per year!

Single Partskeeper Unit

- Includes one case
- 3 mounting styles: under shelf, inset into shelf, or stacked
- 14"D x 18"W x 5"H



Description	Part#
Single Partskeeper	176XXPC



INTERIOR STORAGE & ORGANIZATION

4 Pc. Partskeeper

- 14"D x 18"W x 24"H



Description	Part#
4 Pc. Partskeeper	176XX4PC

5 Pc. Partskeeper

- 14"D x 18"W x 43"H



Description	Part#
5 Pc. Partskeeper	176XX5PC

8 Pc. Partskeeper

- 14"D x 18"W x 43"H



Description	Part#
8 Pc. Partskeeper	176XX8PC

Drawer Cabinets



2-Drawer & 3-Drawer Cabinets:

- Latching drawers with ball bearing slides
- Includes key lock for security
- Cabinets can be individually mounted to shelves or stacked on floor
- 12.5"D x 18.5"W x 10.5"H

9-Drawer Cabinet:

- Rattle-free plastic drawers with dividers
- Includes built-in drawer catch
- 12.5"D x 18.5"W x 10.5"H



INTERIOR STORAGE & ORGANIZATION

2-Drawer Cabinet

3-Drawer Cabinet

9-Drawer Cabinet



Description	Part#
2-Drawer Cabinet	876XX2DC

Description	Part#
3-Drawer Cabinet	876XX3DC

Description	Part#
9-Drawer Cabinet	876XX9DC

Locking Doors



Description	Part#
36" Locking Door	876XX36LD
42" Locking Door	876XX42LD
48" Locking Door	876XX48LD
60" Locking Door	876XX60LD

Dividers (pack of 5)



Description	Part#
10" Adjustable Shelf Dividers	876XX10D
12" Adjustable Shelf Dividers	876XX12D
14" Adjustable Shelf Dividers	876XX14D

Bins



Description	Part#
10"D Plastic Bin	876XX10B
12"D Plastic Bin	876XX12B
14"D Plastic Bin	876XX14B
Cross Dividers (set of 2)	876XXBD

INTERIOR STORAGE & ORGANIZATION

Ladder Hook



Description	Part#
Ladder Hook	876XXLH

Swivel Hook



Description	Part#
Swivel Hook	864XXSW

Fixed Hook



Description	Part#
Fixed Hook	864XXFH

Cab Accessories



Cab Organizer Box



Description	Part#
Cab Organizer Box with Raise	876GXCB

3-Slot Paper Holder



Description	Part#
Steel 3-Slot Paper Holder	876XX3PH

First-Aid Kit



Description	Part#
First-Aid Kit With Holder	864XXFA

Seat Covers

- Custom-fit
- Tough Cordura fabric



Description	Part#
Seat Covers (set of 2)	876GXSC

Hard Hat Holder



Description	Part#
Hard Hat Holder	876XXHH

Triangle Kit



Description	Part#
Triangle Kit	876XXTK

Four Level Bottle Holder:

- For 30lb refrigerant tanks

Small Bottle Holder:

- For MC tanks

Large Bottle Holder:

- For B tanks and nitrogen tanks

Four Level
Bottle
Holder



Description	Part#
Four Level Bottle Holder	876XX4BH



INTERIOR STORAGE & ORGANIZATION

Small
Bottle Holder



Description	Part#
Small Bottle Holder	864XXSBH

Large
Bottle Holder



Description	Part#
Large Bottle Holder	864XXLBH

Roof Equipment



Clamp Down Ladder Rack

- Includes front, middle and rear crossbars for long and short ladders
- Makes loading and unloading ladders an easy, one-person operation
- Ladders are restrained by rotating handle and padlock can be added for extra security



Model

Clamp Down Ladder Rack

Part#

376GXCR

Cargo Racks

- Rust-free aluminum construction
- Includes ladder stops & straps
- Access ladder available



Add an optional rear roller bar

Model

2 Bar Rack

3 Bar Rack

Rear Roller

Part#

395GX2B

395GX3B

395GXRR

Roof Decks

- Heavy duty anodized aluminum construction
- Aerodynamically designed
- Includes rear roller



Model	Part#
Roof Deck	374GXR

Catwalk Plank

(optional)

- Rust-free gripstrut aluminum
- Add to cargo rack or roof deck



Model	Part#
12"W Gripstrut Catwalk	319XXCW

Roof Equipment



Access Ladder

- Heavy duty extruded aluminum
- Contoured to fit Express/Savana



Description	Part#
Access Ladder	774GXAL

Conduit Carrier

- 5" square rigid one piece design
- White powder-coated aluminum with black end caps
- Inside length of 10' 1"
- Lockable
- Add to any ladder rack



Description	Part#
Conduit Carrier	774XXCT

Running Boards

- Black powder-coated aluminum
- Wide tubular design
- 98" passenger's board & 36" driver's board



Description	Part#
Running Boards	760GXSRB

Hitch Step

- Black powder-coated steel
- Assists in rear entry



Description	Part#
Hitch Step	770XXHS

Commercial Accessories



Tow Hitches

- Class III (600 lb tongue weight, 6000 lb trailer weight)
- 4-way flat & 7-way wiring systems



Duplex 4-Way Flat & 7-Way Wiring

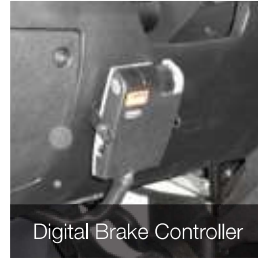

Digital Brake Controller



Description	Part#
Hitch – Class III Hitch for All Models	706GXTH
4-Way Flat Wiring Kit	506GX4TC
Duplex 7-way/4-way Wiring Kit*	506GX7TC
Digital Brake Controller	506XXTBC

* WARNING: Requires a Digital Brake Controller to enable trailer brakes.

Regular 135" WB

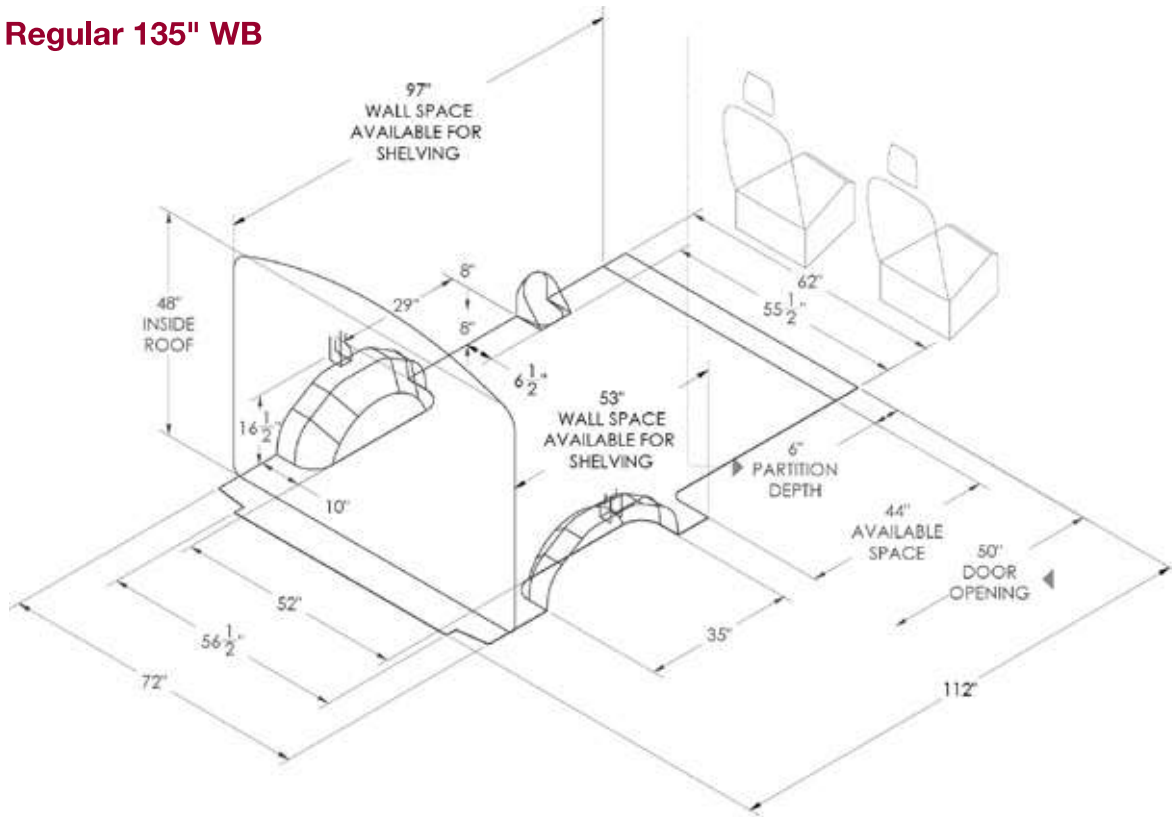

Extended 155" WB

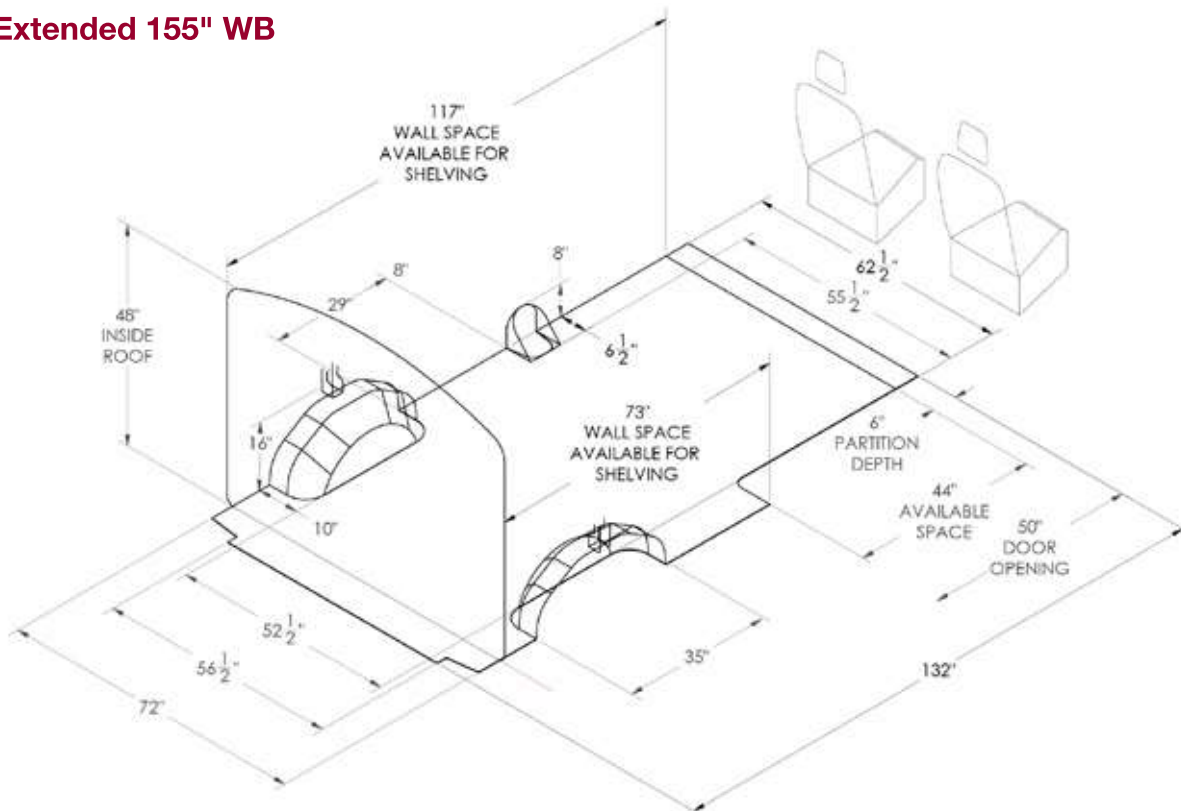



Express & Savana

UPFIT GUIDE

Your Express & Savana Customizing Starts Here.

Let Advantage Outfitters make your van work ready!



4,000+

Vans Upfitted
Per Year

99.5%

Order
Accuracy

95%

Stock Orders
Completed in
48 Hours or Less



Advantage
OUTFITTERS



Serving the Mid-Atlantic region

New York • New Jersey • Connecticut • Pennsylvania

Contact Your Chevrolet/GMC Dealer

866.925.4844

www.advantageoutfitters.com

255 West Street
South Hackensack, NJ 07606

107 E. Hawthorne Avenue
Valley Stream, NY 11580