

# Metris

UPFITTING AND ACCESSORIES



*WORK VEHICLES THAT WORK BETTER!*





# Who We Are

Advantage Outfitters is a commercial vehicle upfitter, specializing in storage equipment and accessories for cargo vans. With 15+ years of experience, we have earned the trust of contractors, trade fleets, utilities, municipalities, vehicle dealers, and leasing companies. We are defined by our strong team spirit and our passion for making our customers happy. Our entire team is committed to making your work vehicles work better!

## Our Team



*Real People.  
Real Passion.*

## Our Service



## Our Facilities



866.925.4844

fax: 800.925.2095

[sales@advantageoutfitters.com](mailto:sales@advantageoutfitters.com)

[www.advantageoutfitters.com](http://www.advantageoutfitters.com)

New York • New Jersey • Connecticut

# What's the Advantage?

## We make it easy:

- Simplified layout and design process
- Technical support and configuration assistance

## We make it fast:

- Everything in this catalog is in stock
- Installs within 48 hours or less

## We make it last:

- Certified and trained Installers
- Lifetime Installation Warranty

## Read what our customers say about us!

"they are a well coordinated team, from sales to technical support to installation"

–David M.

"very well run and efficient operation, AAA+++ customer service"

–Eric S.

"great deal and very smooth transaction, everyone was very helpful with my order from start to finish"

–Nick C.

"I couldn't have been more impressed with their attention to detail"

–Daniel S.

"superb customer service"

–Glenn M.

Certified Mercedes-Benz

**MASTER  
UPFITTER**

Onsite Installation Available!



# Interior Finishing



## Wall & Door Liners

- Protect your vehicle investment
- 3/16" gray plastic
- Highly durable & impact resistant

Note: Full interior liner kits and insulation kits are available. Call for details.



Model	Wall Liners Part#	Door Panels Part#
Regular WB	601M0WL	601M0DP
Extended WB	601M0EWL	601M0DP

INTERIOR FINISHING

## Logistics Kits

### Aluminum Lashing Rail

- Durable & versatile
- Includes 5 movable tie-down rings
- Ratchet straps also available



Model	Part#
Single Level L-Track	842MOLK

## Floor Protection

### Rubber Floor Mat:

- 1/4" virgin rubber resists oils and chemicals
- Saves knees and increases traction
- One piece seamless



Rubber Floor



StabiliGrip Floor

### StabiliGrip Floor:

- 3/8" hard plastic with fiberglass reinforcement
- Provides firm base for tools and equipment
- Durable, non-skid surface

### Diamond Plate Aluminum:

- 1/8" aluminum for lasting durability
- Superior impact & puncture resistance



Side Door Sill (optional)



Rear Door Sill (optional)



Diamond Plate Aluminum

### Door Sills (optional):

- Custom fit, heavy-duty diamond plate aluminum sill plates

Model	Rubber Floor Mat Part#	StabiliGrip Floor Part#	Diamond Plate Aluminum Part#
Regular WB	654M0RM	654M0SG	698M0DP
Extended WB	654M0ERM	654M0ESG	698M0EDP

Description	Door Sill Part#
Rear & Side Sliding Doors	654M0RSS

## Interior Lighting

- High intensity 2' LED light
- 800 lumens
- Ultra low power draw
- Wired with OEM switch

Description	Part#
Single 2' LED light	452XXLD2



# Safety Partitions



SAFETY & SECURITY



## Partition with Perforated Window

- Galvanized steel
- Contoured design with 10" setback gives maximum seatback travel & floor space
- Mesh upper for visibility into rear

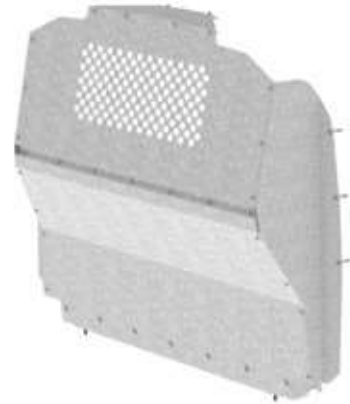

Description	Part#
Partition with Perforated Window	276M0WP

## Wire Mesh Partition

- Black painted mesh
- Contoured design with 10" setback gives maximum seatback travel & floor space



Description	Part#
Wire Mesh Partition	276M0MP

## MaxView Partition

- Composite construction
- Contoured design with 10" setback gives maximum seatback travel & floor space
- Clear upper for visibility into rear



Description	Part#
MaxView Partition	276M0CWP

## Door Security

### Slick Locks

- High security hasps use factory mounting points
- Solid steel “puck” style locks included
- Custom fit for drill-free installation



Description	Part#
Cargo Doors (set of 2)	788M0SL

## Reverse/Driving Safety

### Reverse Sensors

- 4 bumper mount sensors
- Digital LED display with audio alarm



Description	Part#
Reverse Sensors	580XXRVS

### Back-up Alarm

- 97 dba
- Commercial grade



Description	Part#
Back-up Alarm	594XXBU

### Window Grills

- Black painted wire mesh construction

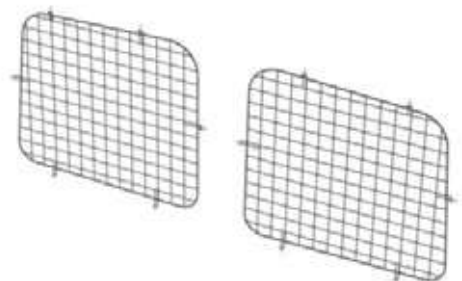

Description	Part#
Rear Doors	876M0RG





# Strong... Lightweight... Quiet... Customizable...

Up to 40% weight savings versus  
comparable steel packages

Load tested to 1200 lbs



## Here's what our customers say about their upfitted vans

"my technicians are able to keep  
the truck organized, which increases  
our overall efficiency"

– Michael S.

"you really helped us get the maximum  
benefit out of our vehicles"

– Michael R.

"ready-made solutions that are lighter,  
stronger, and more durable than anything  
we could have come up with"

– Greg W.

**LIMITED  
LIFETIME  
WARRANTY**  
★ ★ ★

**RANGER**<sup>TM</sup>  
DESIGN

# Shelving Packages



## Base Package



### Driver's side includes:

- (1) 45"H x 72"L 3-shelf shelving unit

### Passenger's side includes:

- (1) 45"H x 36"L 3-shelf shelving unit



INTERIOR STORAGE & ORGANIZATION

Description	Part#
Base Package	276M0BP

# General Service Package



**Driver's side includes:**

- (1) 45"H x 72"L 3-shelf shelving unit
- (10) adjustable 3" rattle-free dividers
- (2) 18.5"W x 10.5"H 2-drawer cabinets
- (1) fixed hook

**Passenger's side includes:**

- (1) 45"H x 36"L 3-shelf shelving unit
- (3) 14"D x 12"W plastic bins
- (1) swivel hook

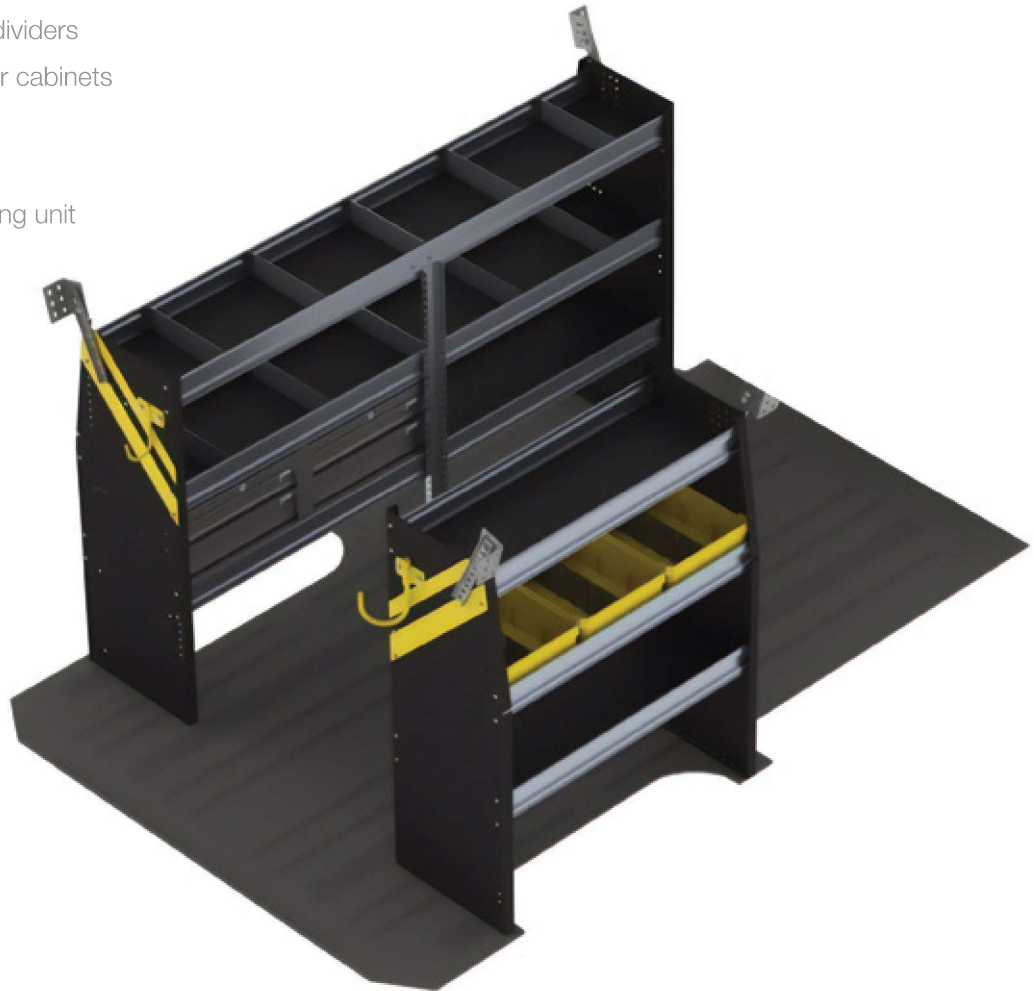

INTERIOR STORAGE & ORGANIZATION

Description	Part#
General Service Package	276M0GSP

# Shelving Packages



## HVAC Package



### Driver's side includes:

- (1) 45"H x 72"L 3-shelf shelving unit
- (6) 12"D x 12"W plastic bins
- (2) 18.5"W x 10.5"H 2-drawer cabinets
- (1) large gas bottle holder
- (1) fixed hook

### Passenger's side includes:

- (1) 45"H x 36"L 3-shelf shelving unit
- (10) adjustable 3" rattle-free dividers
- (1) 43"H x 10.5"W 4-tier refrigerant rack for bottles
- (1) swivel hook

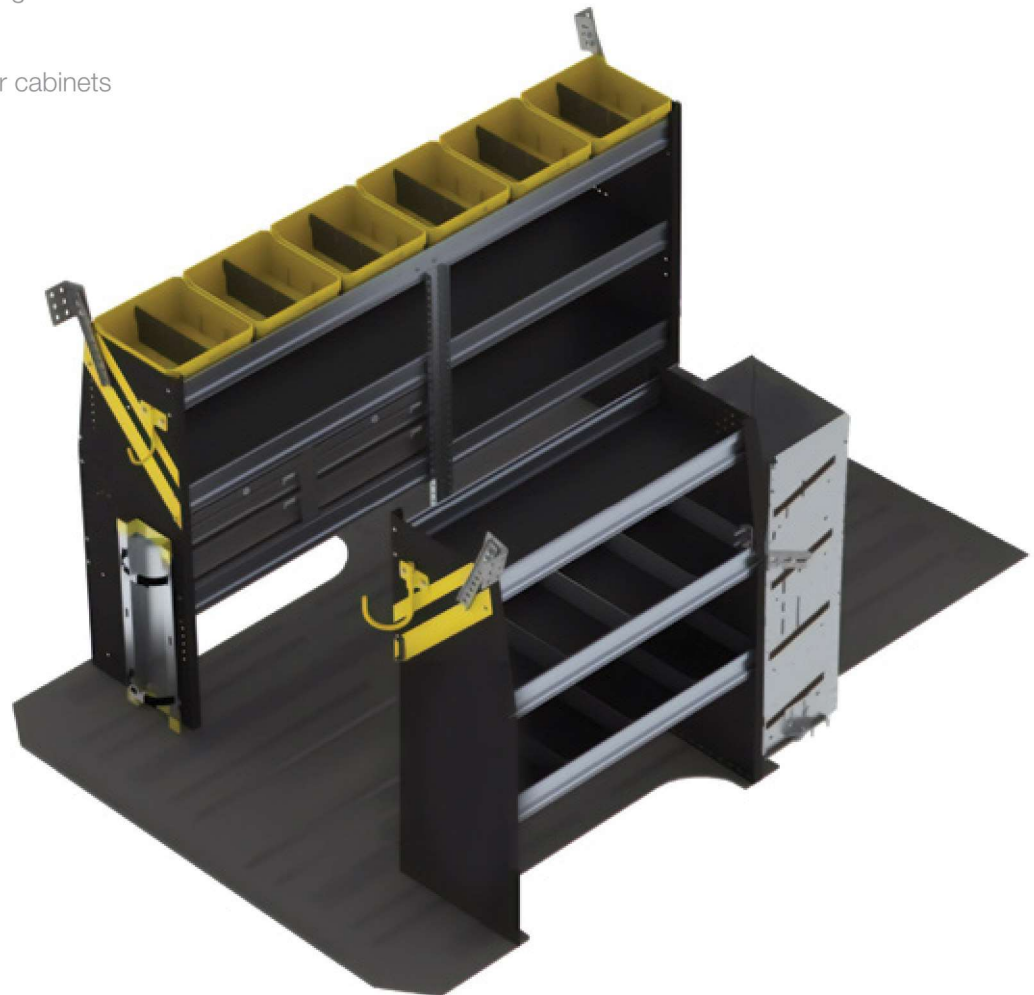

INTERIOR STORAGE & ORGANIZATION

Description	Part#
HVAC Package	276M0HP

# Plumbing Package



**Driver's side includes:**

- (1) 45"H x 72"L 3-shelf shelving unit
- (5) adjustable 3" rattle-free dividers
- (1) 18.5"W x 10.5"H 2-drawer cabinet
- (1) 18.5"W x 10.5"H 3-drawer cabinet
- (1) large gas bottle holder
- (1) fixed hook

**Passenger's side includes:**

- (1) 45"H x 36"L 3-shelf shelving unit
- (6) 14"D x 12"W plastic bins
- (3) cross dividers for bins
- (1) large gas bottle holder
- (1) swivel hook



INTERIOR STORAGE & ORGANIZATION

Description	Part#
Plumbing Package	276MOPP

# Shelving Packages



## Electrical Package



### Driver's side includes:

- (1) 45"H x 72"L 3-shelf shelving unit
- (6) 12"D x 12"W plastic bins
- (2) 11"H x 36"L locking cabinets
- (1) 18.5"W x 10.5"H 3-drawer cabinet
- (1) wire reel holder
- (1) fixed hook

### Passenger's side includes:

- (1) 45"H x 36"L 3-shelf shelving unit
- (10) adjustable 3" rattle-free dividers
- (1) swivel hook

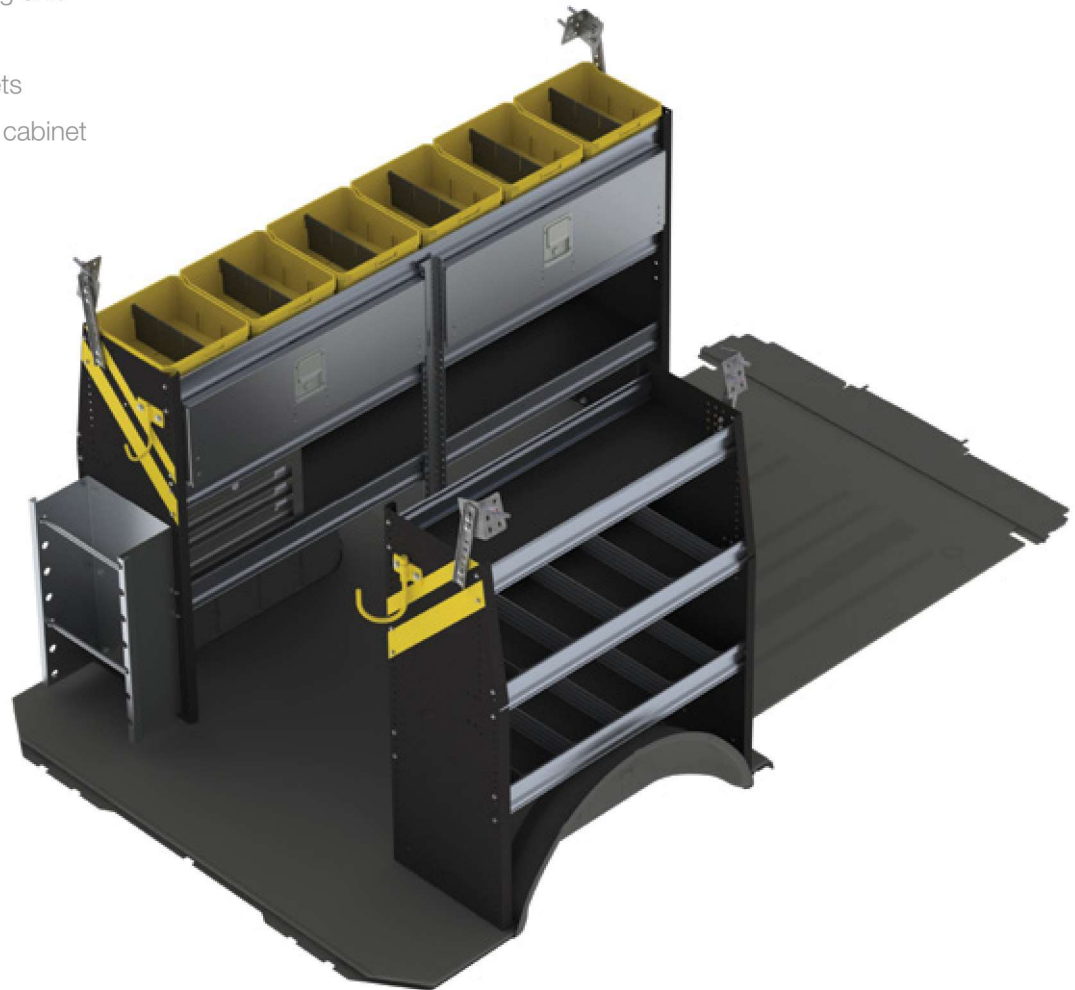

INTERIOR STORAGE & ORGANIZATION

Description	Part#
Electrical Package	276M0EP

## Delivery Package



### Driver's side includes:

- (1) 45"H x 72"L 2-shelf unit with folding shelves

### Passenger's side includes:

- (1) 45"H x 36"L 2-shelf unit with folding shelves



INTERIOR STORAGE & ORGANIZATION

- Folding shelves keep aisle clear when not in use
- Gas shock holds shelf in either up or down position
  - no latches or rattles
- Capacity is 40 lbs per linear foot
- Shelves are 20" deep

Description	Part#
Delivery Package	176M0DP

# Specialty Upfits





## Aluminum Shelving

Ultra-lightweight all-aluminum packages are also available!



**Weight saving equipment reduces total cost of ownership:**

-  Optimize fuel economy by decreasing overall van mass
-  Reduce vehicle maintenance and repairs caused by weight overload
-  Increase payload without sacrificing quality — it's a benefit offered only by aluminum



INTERIOR STORAGE & ORGANIZATION

## Customized Interiors

Climate Control & Ventilation • Inverters & Power Systems  
Workbenches & Desks • Warning & Scene Lighting

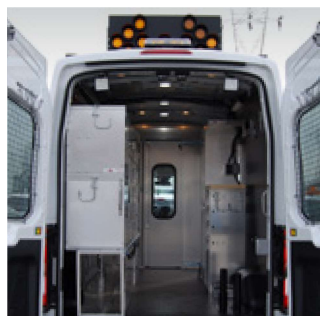

Contact us for further information on all-aluminum shelving and customized interiors.



## Save Time and Get Organized!

Access your most common items without even entering your vehicle.



### Jumbo Tool Drawer

- 320 lb capacity
- Open interior for tool bags & cases
- 16"W x 48"L x 20"H



Description	Part#
Jumbo Tool Drawer	176XXJTD

### Parts Drawer

- 150 lb capacity
- Dividers for parts and hand tools
- Stack 1, 2 or 3 above your jumbo tool drawer
- 12"W x 48"L x 6"H



Description	Part#
Parts Drawer	176XXPD

### Top Tray

- Turn your parts drawer top into additional organization
- Add 3 crates (optional)
- 12"W x 48"L x 4"H



Description	Part#
Top Tray	176XXTT
Top Tray With Crates	176XXTWC

### Add a Worktop to Your Drawer System

- 18"D x 48"W hardwood butcher block top



Description	Part#
Drawer System Worktop	176XXWT

### Add a Raise For Long Pipe or Lumber

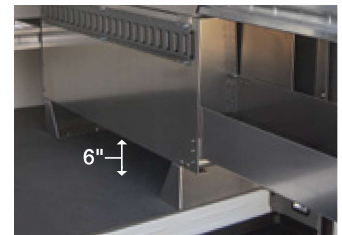

Description	Part#
Raises (set of 2)	176XX6R

# Partskeepers



## Be Efficient!

Saving just 5 minutes per day will gain you 21 hours per year!

## Single Partskeeper Unit

- Includes one case
- 3 mounting styles: under shelf, inset into shelf, or stacked
- 14"D x 18"W x 5"H



Description	Part#
Single Partskeeper	176XXPC



INTERIOR STORAGE & ORGANIZATION

## 4 Pc. Partskeeper

- 14"D x 18"W x 24"H



Description	Part#
4 Pc. Partskeeper	176XX4PC

## 5 Pc. Partskeeper

- 14"D x 18"W x 43"H



Description	Part#
5 Pc. Partskeeper	176XX5PC

## 8 Pc. Partskeeper

- 14"D x 18"W x 43"H



Description	Part#
8 Pc. Partskeeper	176XX8PC

## 2-Drawer & 3-Drawer Cabinets:

- Latching drawers with ball bearing slides
- Includes key lock for security
- Cabinets can be individually mounted to shelves or stacked on floor
- 12.5"D x 18.5"W x 10.5"H

## 9-Drawer Cabinet:

- Rattle-free plastic drawers with dividers
- Includes built-in drawer catch
- 12.5"D x 18.5"W x 10.5"H



2-Drawer Cabinet

3-Drawer Cabinet

9-Drawer Cabinet



Description	Part#
2-Drawer Cabinet	876XX2DC

Description	Part#
3-Drawer Cabinet	876XX3DC

Description	Part#
9-Drawer Cabinet	876XX9DC

# Shelving Accessories



## Locking Doors



Description	Part#
36" Locking Door	876XX36LD
42" Locking Door	876XX42LD
48" Locking Door	876XX48LD
60" Locking Door	876XX60LD

## Dividers (pack of 5)



Description	Part#
10" Adjustable Shelf Dividers	876XX10D
12" Adjustable Shelf Dividers	876XX12D
14" Adjustable Shelf Dividers	876XX14D

## Bins



Description	Part#
10"D Plastic Bin	876XX10B
12"D Plastic Bin	876XX12B
14"D Plastic Bin	876XX14B
Cross Dividers (set of 2)	876XXBD

INTERIOR STORAGE & ORGANIZATION

## Ladder Hook



Description	Part#
Ladder Hook	876XXLH

## Swivel Hook



Description	Part#
Swivel Hook	864XXSW

## Fixed Hook



Description	Part#
Fixed Hook	864XXFH

## Cab Organizer Box



Description	Part#
Cab Organizer Box with Raise	876XXMCB

## 3-Slot Paper Holder



Description	Part#
Steel 3-Slot Paper Holder	876XX3PH

## First-Aid Kit



Description	Part#
First-Aid Kit With Holder	864XXFA

## Seat Covers

- Custom-fit
- Tough Cordura fabric



Description	Part#
Seat Covers (set of 2)	876M0SC

## Hard Hat Holder



Description	Part#
Hard Hat Holder	876XXHH

## Triangle Kit



Description	Part#
Triangle Kit	876XXTK

# Bottle Holders



## Four Level Bottle Holder:

- For 30lb refrigerant tanks

## Small Bottle Holder:

- For MC tanks

## Large Bottle Holder:

- For B tanks and nitrogen tanks

## Four Level Bottle Holder



Description	Part#
Four Level Bottle Holder	876XX4BH



## Small Bottle Holder



Description	Part#
Small Bottle Holder	864XXSBH

## Large Bottle Holder



Description	Part#
Large Bottle Holder	864XXLBH

## Clamp Down Ladder Rack

- Includes front, middle and rear crossbars for long and short ladders
- Makes loading and unloading ladders an easy, one-person operation
- Ladders are restrained by rotating handle and padlock can be added for extra security



Model	Part#
Clamp Down Ladder Rack	376M0CR

## Cargo Racks

- Rust-free aluminum construction
- Includes ladder stops & straps



Model	Part#
2 Bar Rack	395M02B
3 Bar Rack	395M03B

# Roof Equipment



## Roof Decks

- Heavy duty anodized aluminum construction
- Aerodynamically designed
- Includes rear roller



Description	Part#
Roof Deck	376M0RD

## Conduit Carrier

- 5" square rigid one piece design
- White powder-coated aluminum with black end caps
- Inside length of 10' 1"
- Lockable
- Add to any ladder rack



Description	Part#
Conduit Carrier	774XXCT



## Windows

- OEM fit
- Light smoke tint



COMMERCIAL ACCESSORIES

Description	Part#
Rear LH & RH	743M0RW
Driver's Side Forward	743M0DSFW
Sliding Door	743M0SDW
Porthole	732XXPW

# Commercial Accessories



## Tow Hitches

- Class III (600 lb tongue weight, 6000 lb trailer weight)
- 4-way flat & 7-way wiring systems



Description	Part#
Hitch	706M0TH
4-Way Flat Wiring Kit	506M04TC

COMMERCIAL ACCESSORIES

## Hitch Step

- Black powder-coated steel
- Assists in rear entry



Description	Part#
Hitch Step	770XXHS

## 126" WB

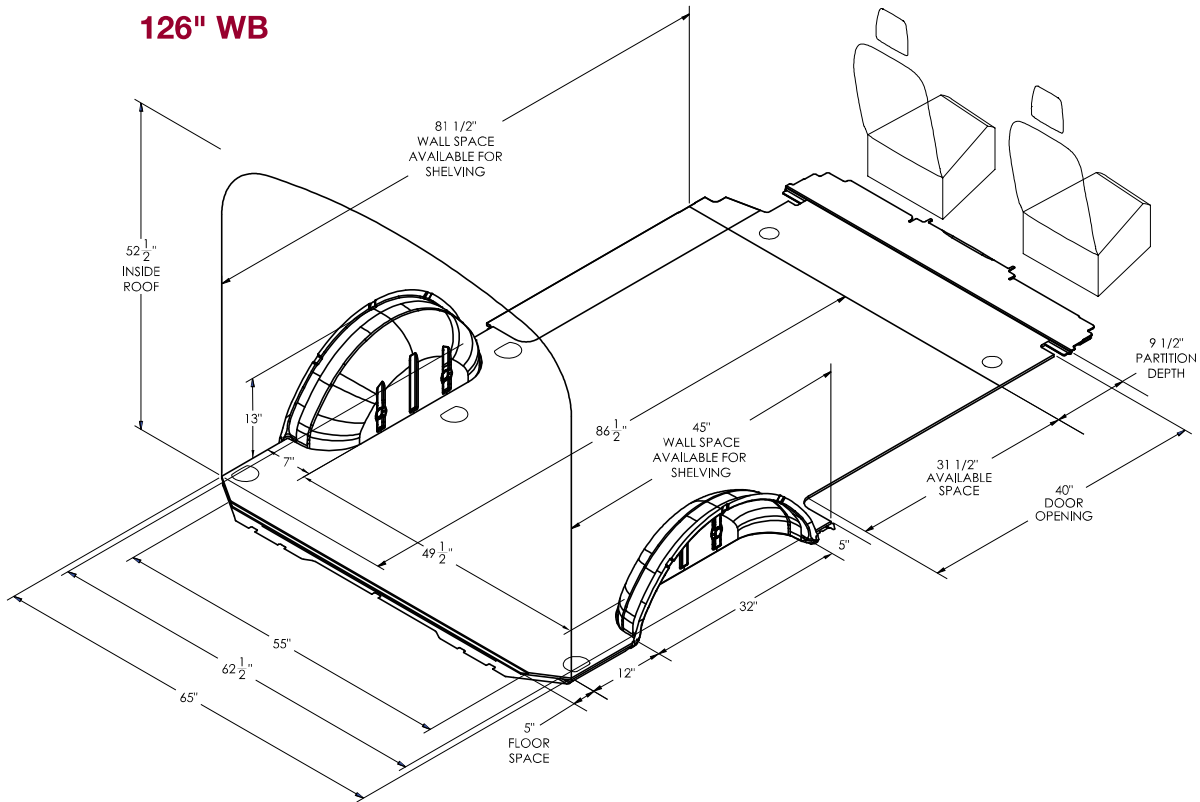

## 135" WB

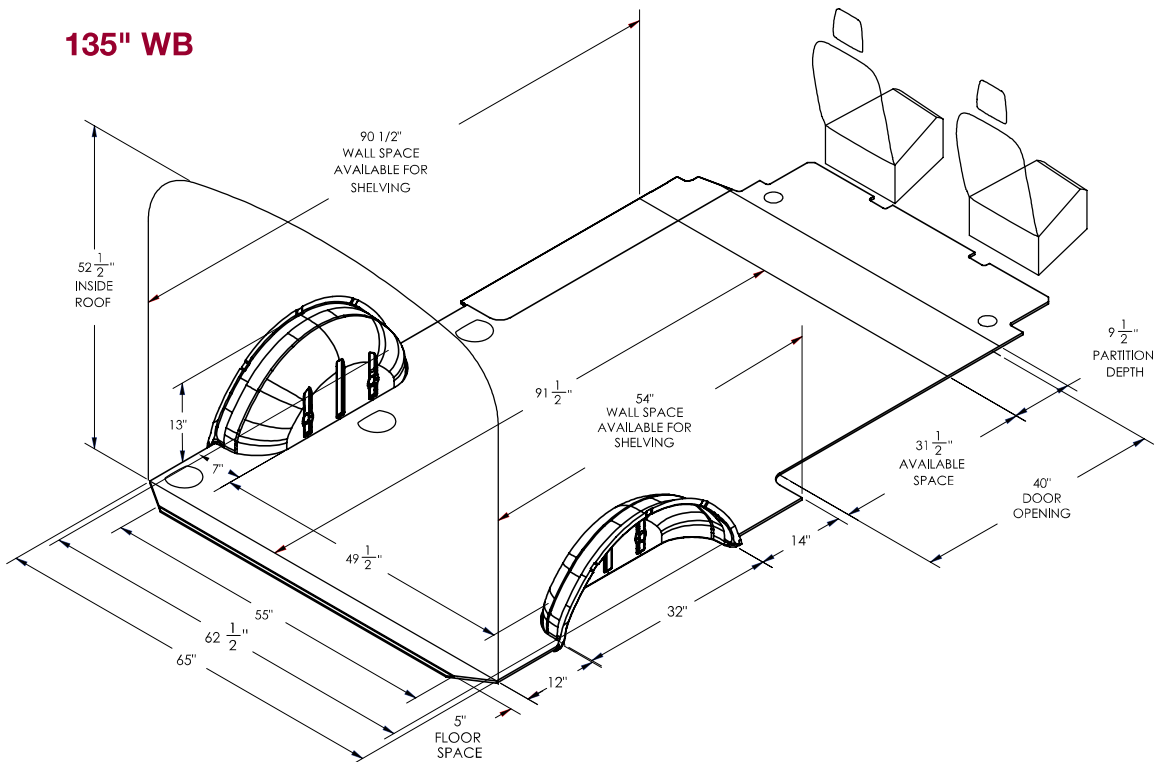



# Metris

UPFIT GUIDE

## Your Metris Customizing Starts Here.

Let Advantage Outfitters make your van work ready!

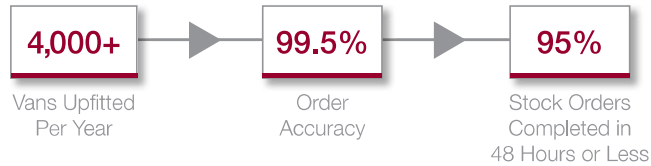

Certified Mercedes-Benz

**MASTER UPFITTER**

*Serving the tri-state region*

New York • New Jersey • Connecticut

Contact Your Mercedes Dealer

866.925.4844

[www.advantageoutfitters.com](http://www.advantageoutfitters.com)

255 West Street  
South Hackensack, NJ 07606

107 E. Hawthorne Avenue  
Valley Stream, NY 11580